



800.248.6564

B&W Trailer Hitches | 1216 Hawaii Road | Humboldt, KS 66748

Live chat with us on our website bwtrailerhitches.com



BW

**THE OFFICIAL HITCH OF
MAJOR LEAGUE FISHING,
HARD-WORKING RANCHERS,
NATIONAL PARK LOVERS,
WEEKEND WARRIORS, AND**

FREEDOM





ALL-AMERICAN APPLIES TO OUR PRODUCTS AND OUR VALUES

The only thing keeping your truck and your trailer connected are those relatively small pieces of engineered steel. The hitch you choose matters not only to your safety, but to the safety of our roads.

That's why we treat the manufacture of your trailer hitch with the respect it deserves. We insist on American-made steel, like the sheet steel made in Burns Harbor, Indiana or the round bar that becomes the gooseneck ball made at a mill in Norfolk, Nebraska. When the strength and flexibility of the steel can mean life or death, we trust the U.S. steel mills with their finely controlled processes and specifications we can trust.

Only in America could a small-town farmer start a business in a garage and watch it grow the way B&W has over the last 35 years. The 600 employees in Humboldt, Kansas are proof that American Manufacturing can compete in a global economy. We are grateful that you have put your trust in us.

Joe Works, Owner



**BUILT FOR
THE DAYS THAT
MATTER MOST.**

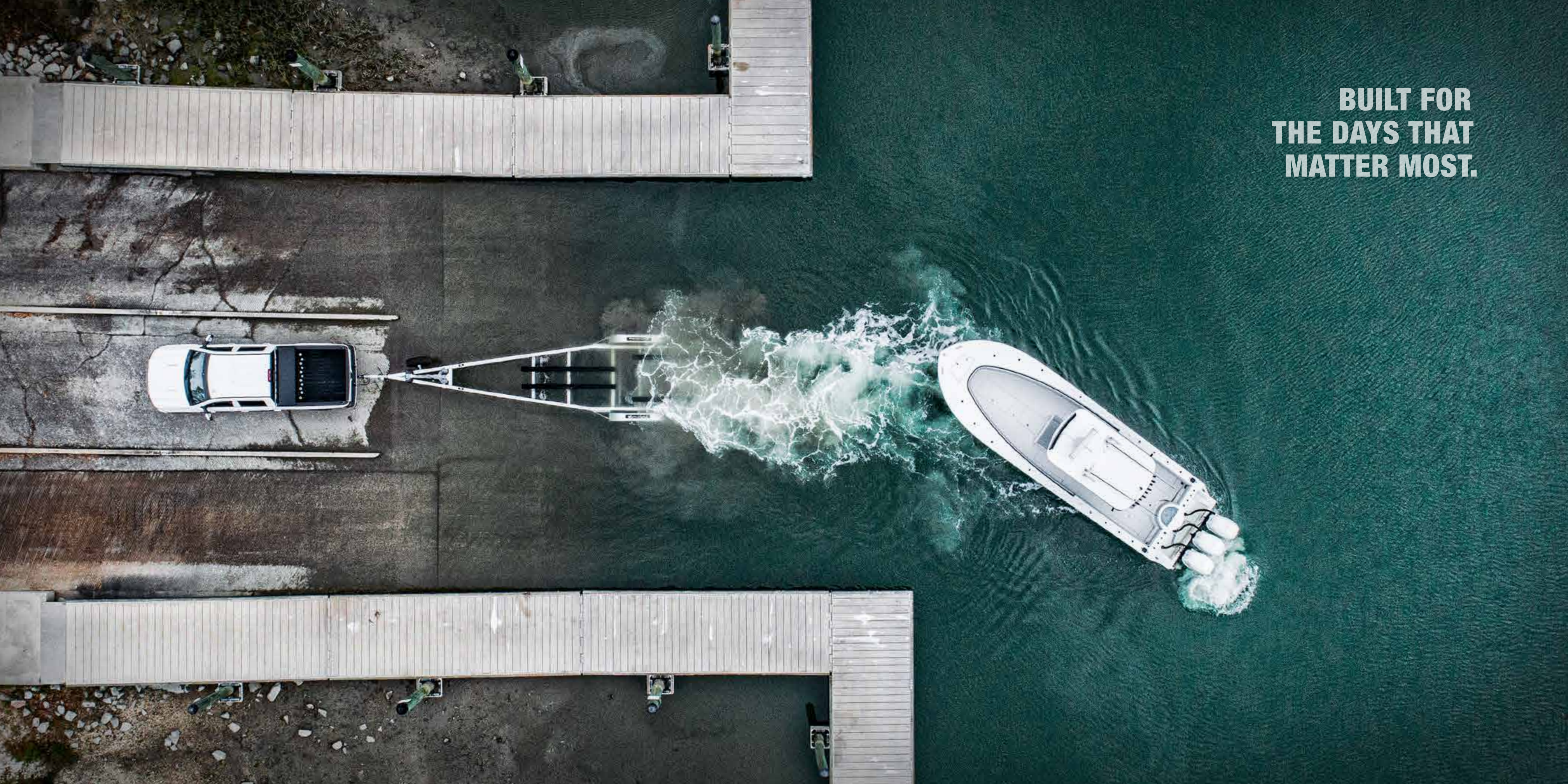



TOW & STOW[®]

ADJUSTABLE BALL MOUNT



CLASS
IV

CLASS
V

- 2" SHANK**
10,000 lb GTW
1,000 lb VTW
- 2½" SHANK**
14,500 lb GTW
1,450 lb VTW
- 3" SHANK**
21,000 lb GTW
2,100 lb VTW

Stainless steel pins

Two-step finish of e-coat and powder-coat for enhanced corrosion resistance inside and out. Also available in chrome.

Multiple ball sizes rotate into place

Dual-process plating for corrosion resistance

BUY A HITCH FOR THE LAST TIME

The Tow and Stow gives you the versatility to swap ball sizes, adjust the height in seconds, and stow it under your vehicle when you're not towing. It's the freedom of knowing you have the equipment for any situation and the confidence that it will do the job. It's everything you ever wanted in a hitch, built to last a lifetime.



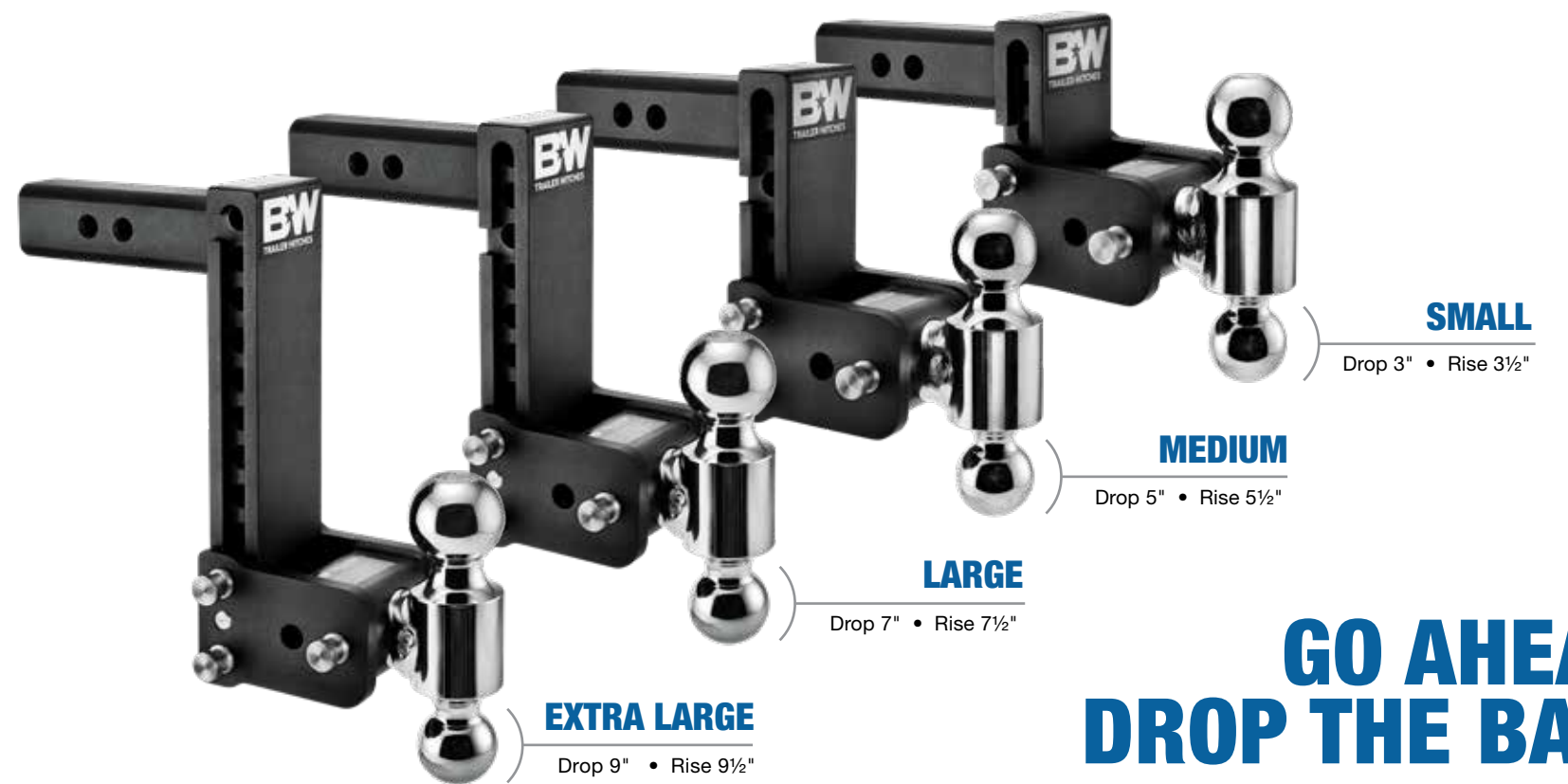

CHANGES BALL SIZES, CHANGES HEIGHT, CHANGES EVERYTHING

**GO AHEAD,
DROP THE BALL**

ADJUST

Raise or lower for level towing.

ROTATE

Multiple ball sizes rotate into place for rapid adaptability.

STOW

Stows under vehicle when not in use: streamlined and shin-safe.

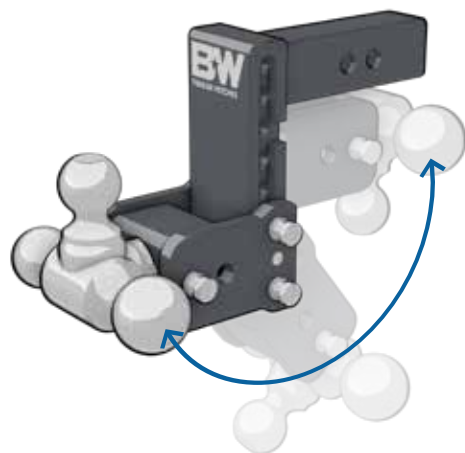
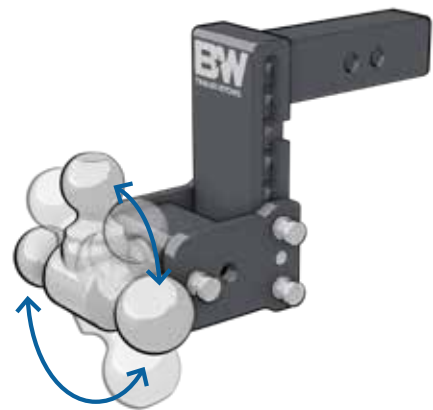
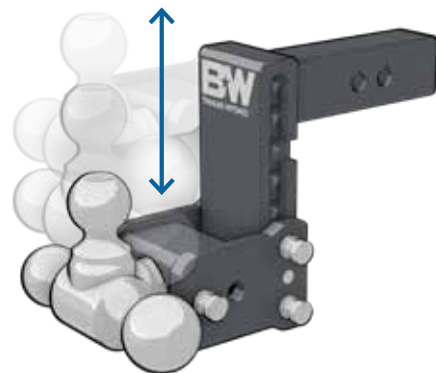

SHANK SIZE		2"				2½"			3"	
		3"	5"	7"	9"	5"	7"	8½"	4½"	7½"
BALL SIZE	DROP	EW	EW	EW	EW	EW	EW	EW	EW	EW
	1½ x 2 x 2½"	● TS10047B ● TS10047C ● TS10047BB	● TS10048B ● TS10048C ● TS10048BB	● TS10049B ● TS10049C	● TS10050B	● TS20048B ● TS20048C	● TS20049B ● TS20049C	● TS20050B	● TS30048B	● TS30049B
	2 x 2½"	● TS10033B ● TS10033C ● TS10033BB	● TS10037B ● TS10037C ● TS10037BB	● TS10040B ● TS10040C	● TS10043B	● TS20037B ● TS20037C	● TS20040B ● TS20040C	● TS20043B	● TS30037B	● TS30040B
	1½ x 2	● TS10035B	● TS10038B							
				● Black Powder Coat		● Chrome		● Licensed Browning Logo		



TAILGATE OF THE FUTURE WITH A HITCH TO MATCH

The MultiPro compatible Tow & Stow is designed specifically for the GMC MultiPro Tailgate. Simply lock it in your receiver and stow the ball assembly behind the hitch. This allows you to keep the hitch on your truck while retaining the ability to use the inner gate and step feature of the tailgate. No other ball mount is engineered to work this seamlessly.



KNOWS WHEN TO GET OUT OF THE WAY

2" SHANK

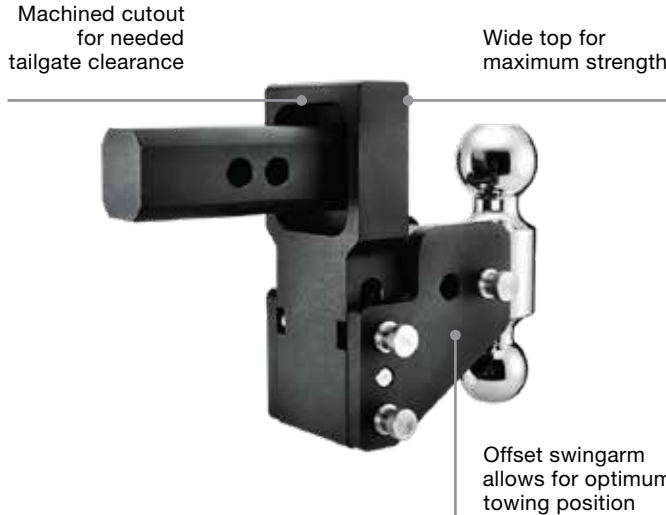

2 1/2" SHANK



Part #	Shank	Drop	Rise	Ball Size
TS10063BMP	2"	2-1/2"	3-1/2"	2" x 2 5/16"
TS10064BMP	2"	2-1/2"	3-1/2"	1 7/8" x 2" x 2 5/16"
TS10065BMP	2"	4-1/2"	5-1/2"	2" x 2 5/16"
TS10066BMP	2"	4-1/2"	5-1/2"	1 7/8" x 2" x 2 5/16"
TS20066BMP	2-1/2"	7"	7-1/2"	2" x 2 5/16"
TS20067BMP	2-1/2"	7"	7-1/2"	1 7/8" x 2" x 2 5/16"



Part #	Shank	Drop	Rise	Ball Diameter
TS10055	2"	8-1/2"	4-1/2"	2"
TS10056	2"	8-1/2"	4-1/2"	2-5/16"
TS20055	2-1/2"	8-1/2"	4-1/2"	2"
TS20056	2-1/2"	8-1/2"	4-1/2"	2-5/16"

THE HEAVYWEIGHT CHAMPION OF YOUR WORLD

Our Tow & Stow Pintle Hitch has all the same features as the Tow & Stow, but it's built to pull even more weight for ranch, construction and other heavy-duty loads. Hookup is super simple — slide your trailer ring over the ball and drop the plate into place to secure it, giving you the ability to haul up to 16,000 pounds.



ADJUST

Raise or lower for level towing.

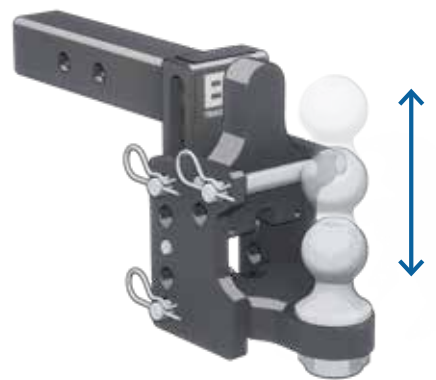

SECURE

Hook the trailer ring over the ball, drop and lock the plate to secure heavier loads than a regular hitch.

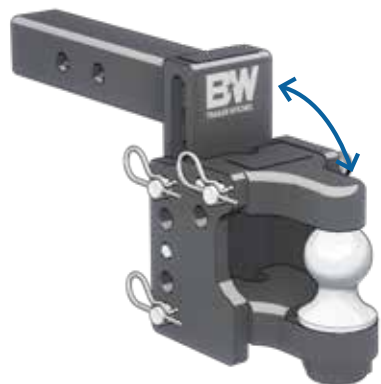

STOW

Stows under vehicle when not in use: streamlined and shin-safe.

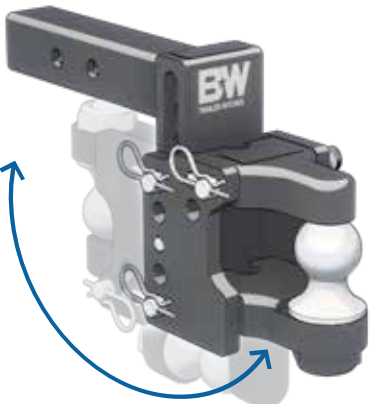



WE WANTED SOMETHING BETTER, SO WE BUILT IT OURSELVES.

From a small garage in 1987, Joe Works and Roger Baker solved a point of frustration for every person who'd ever used a gooseneck ball. Their invention revolutionized an entire industry.

The Turnoverball Gooseneck Hitch was more than a display of American ingenuity. Its success gave two small business owners the chance to prove American manufacturing is more than alive and well. It's the strongest way forward.

As employee-owners, we stand behind every product and are proud of the midwestern values that made B&W.



BW



**BUILT IN THE PROUD
TRADITION OF GETTING THE
JOB DONE, NO MATTER WHAT.**



TURNOVERBALL®

GOOSENECK TOWING

THERE WHEN YOU NEED IT, NEVER WHEN YOU DON'T

The under-bed design keeps the hitch out of sight, and the ball stores in the receiver in seconds for a fully functional bed. It goes from heavy-hauler one minute to out-of-the-way the next.

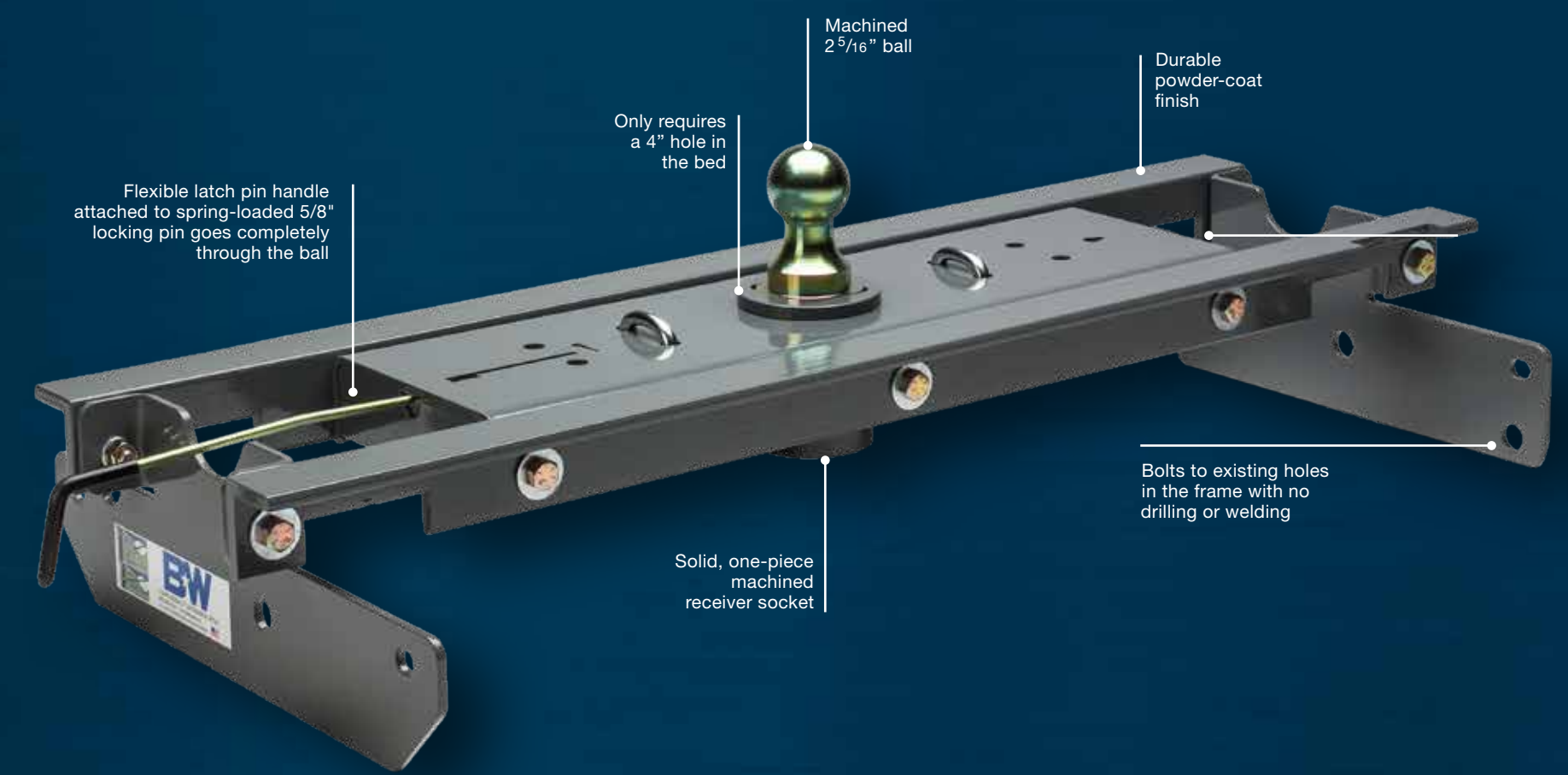



IT'S HIP TO **BE SQUARE**

The Turnoverball provides a strong, under-bed mounting system that bolts directly to the frame of your truck. And the only drilling required is a 4" hole in the bed for the receiver. It's no wonder that every type of trailer owner came forward looking for a solution. That's why we designed square-based accessories for every kind of trailer out there, including a fifth-wheel. It's a perfect solution for hard working multi-taskers who switch trailers but don't want a lot of hassle.



ONE RECEIVER **TO HAUL THEM ALL**



EVEN A 5TH WHEEL HITCH



The single-point Companion is equipped with a square post that fits into the Turnoverball receiver hole in the bed. The Turnoverball latch handle releases a pin that extends through holes in the post. Then, a draw-down bolt on the post is tightened to create upward pressure on the pin creating a snug fit to the bed.



FITTING A SQUARE PEG INTO A ROUND HOLE IS KIND OF OUR THING

While others use a round base and receiver, we like the security of a square receiver. The square base keeps accessories aligned with the truck, so a Companion or four-inch extender is possible.

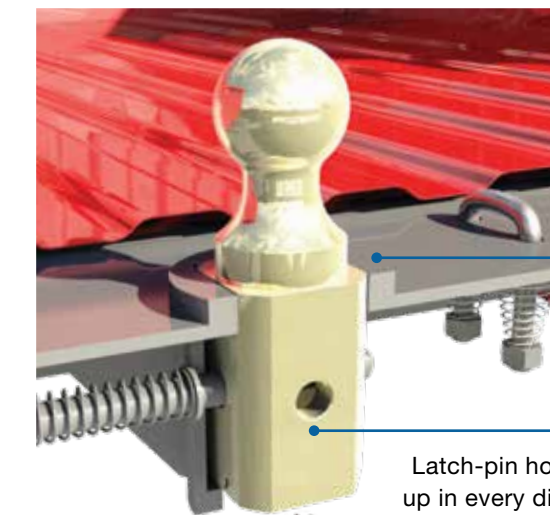

Our tight tolerances have delivered a smooth ride and rattle-free towing for over 30 years.

4" round hole in bed

Latch-pin holes line up in every direction.

The round, open-bottom socket lets dirt escape so it doesn't clog the receiver.

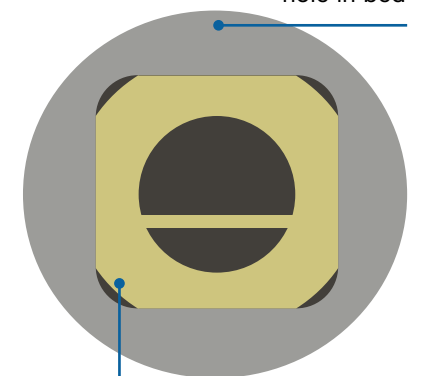

Square accessory base

WHAT'S THE POINT OF A BED IF YOU CAN'T USE IT?

We believe your bed is yours to use – take the kids camping, throw a mower or lumber in the back – you know, the things you bought a truck for in the first place. Your hitch shouldn't get in the way of that. That's why ours never will.





DEFENDER™ LOCKING GOOSENECK COUPLER

GOOSENECK TOWING

STRONGER, FASTER AND MORE SECURE

We've reinvented the coupler on this one. With built-in security features and unrivaled ease of use, the Defender makes towing incredibly easy and is a great theft deterrent.



Automatic latch lets you line up, drop and go

Push-button keyed lock keeps thieves at bay

Cone shaped coupler simplifies lineup and hookup



ANCHORED FOR THE LONG HAUL

The grip latch handle keeps your hands grease-free, while the ultra-heavy-duty construction and safety chains give you peace of mind with your OEM setup.



OEM BALL & SAFETY CHAIN KIT

GOOSENECK TOWING





GET MORE ROOM TO MOVE WITH B&W EXTENDERS



OFFSETS BALL 4"

- An accessory to the Turnoverball®
- Moves pivot point rearward four inches
- Removable
- Made from 3/4" steel plate



OFFSETS TRAILER 10"

- Self-aligning coupler design
- Heavy wall tube with internal gussets provides maximum strength
- Easier hook ups with more clearance at the tailgate and trailer
- Fits all standard 4" I.D. round trailer tubes
- Funnel shaped coupler assists in aligning the trailer with the hitch.
- Accommodates padlock for theft prevention



**FREEDOM IS IN
EVERYTHING WE DO.**





COMPANION™

FIFTH WHEEL HITCH

FIRST IN COMMAND OF THE FIFTH WHEEL

Sure, the truck and trailer are important, but never underestimate the role the hitch plays in the towing experience. We built our line of fifth wheel hitches with the goal of a smooth ride, so you can enjoy your time on the road.

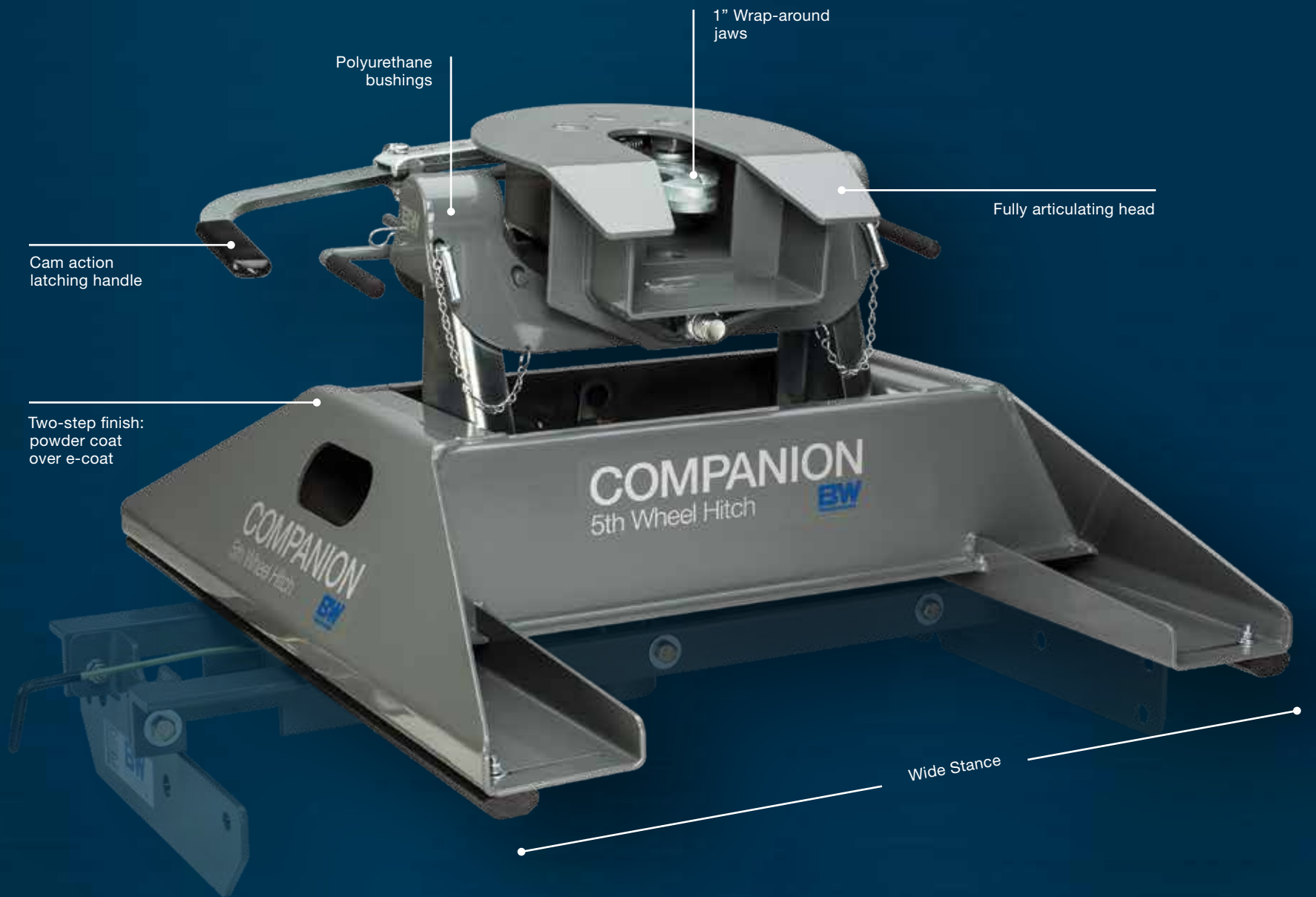

WE INVENTED SMOOTH TOWING

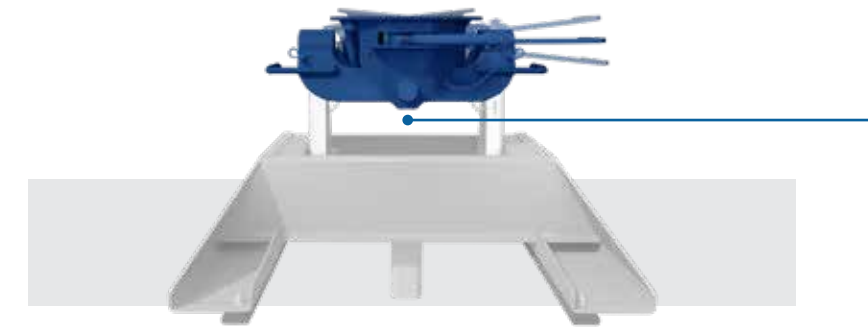

Hydraulic shock absorber allows smooth side-to-side movement without jarring.



Polyurethane bushings provide a quiet, rattle-free towing experience.



1" thick wrap-around jaws eliminate sloppy starts and stops with a tolerance of about the thickness of a piece of paper

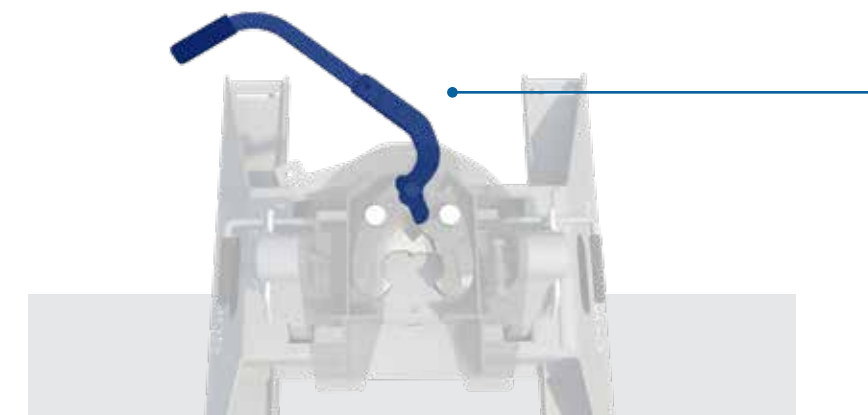

Cam-action latching handle for easy release, even on unlevel surface.

A HITCH FOR EVERY TRUCK

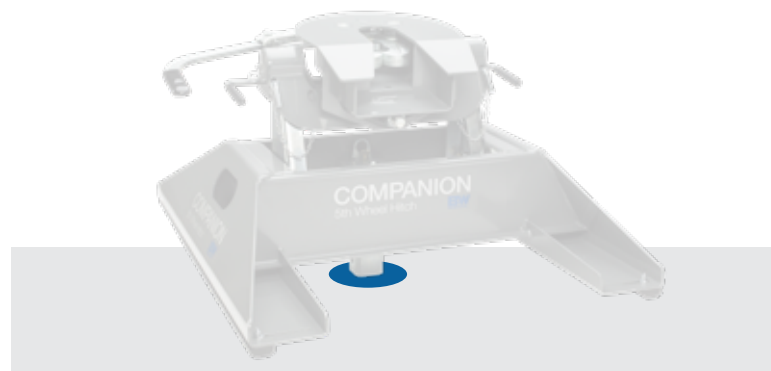

SINGLE-POINT

When we invented the Turnoverball Gooseneck Hitch over 30 years ago, customers loved being able to turn the ball over and have their truck bed free. Our Companion Fifth Wheel Hitch uses the same under-bed mounting system as the original Turnoverball and has a single-point attachment. When you're not using it, the Companion is removable and your truck is free to haul something else.



PUCKS

Some trucks come equipped with factory installed OEM mounting systems. These mounting systems use 'pucks' arranged at different spacing as a means for attachment. We build Companion bases that work with these pucks at the four corners. Simply drop the base in the pucks, turn the handle, and pin.



RAILS

While permanent rails aren't for everybody, they are still a preferred method of attachment for some. Our Patriot line was born when customers asked us to take the unique features of the Companion, but mount them on industry standard rails. So, we did. The Patriot, like all of our products, is made in America.





TO SLIDE OR NOT TO SLIDE?

A sliding hitch allows you to move the pivot point of the hitch rearward when maneuvering so that your trailer nose doesn't hit the cab of your truck. There are several schools of thought on this question, but it really comes down to personal preference. If you have a short-bed truck and you anticipate doing a lot of tight turns and maneuvering into campgrounds, you should consider a slider.

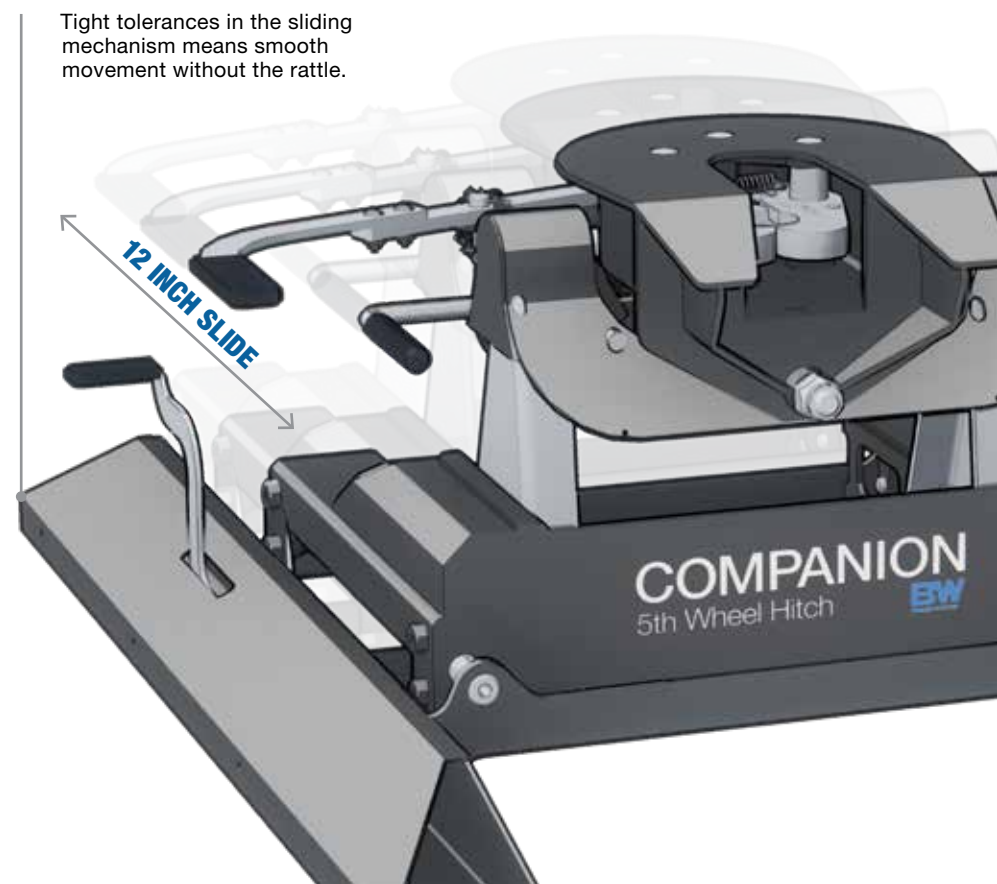

Method of Attachment	Name	Part #	WEIGHT RATING		ADJUSTMENTS		Slider
			GTW	VTW	Vertical	Front to Back	
SINGLE-POINT	Companion	RVK3500	20,000 lb	5,000 lb	16.25" - 18.25"	4"	
	Companion for Flatbeds	RVK3050	25,000 lb	6,250 lb	10.5"	0"	
	Companion Slider	RVK3405	20,000 lb	5,000 lb	17" - 19"	2"	X
PUCKS	FORD						
	20K Companion	RVK3300	20,000 lb	5,000 lb	16.75" - 18.75"	2"	
	25K Companion	RVK3305	25,000 lb	6,250 lb	16.75" - 18.75"	2"	
	Companion Slider	RVK3370	20,000 lb	5,000 lb	17" - 19"	2"	X
	RAM						
	25K Companion	RVK3600	25,000 lb	6,250 lb	17" - 19"	6"	
	Companion Slider	RVK3670	20,000 lb	5,000 lb	17" - 19"	2"	X
	GM						
	20K Companion 2016-2019 Systems	RVK3700	20,000 lb	5,000 lb	16.75" - 18.75"	2"	
	20K Companion 2020-2021 Systems	RVK3710	20,000 lb	5,000 lb	17" - 19"	2"	
	25K Companion 2016-2019 Systems	RVK3705	25,000 lb	6,250 lb	16.75" - 18.75"	2"	
	25K Companion 2020-2021 Systems	RVK3715	25,000 lb	6,250 lb	17" - 19"	2"	
Companion Slider 2016-2019 Systems	RVK3770	20,000 lb	5,000 lb	17" - 19"	2"	X	
Companion Slider 2020-2021 Systems	RVK3775	20,000 lb	5,000 lb	17" - 19"	2"	X	
RAILS	Patriot 18K Slider	RVK3270	18,000 lb	4,500 lb	17" - 19"	2"	X
	Patriot 18K	RVK3255	18,000 lb	4,500 lb	16" - 19"	4"	
	Patriot 16K	RVK3200	16,000 lb	4,000 lb	16" - 19"	4"	

ACCESSORIES



COMPANION™ COVER RVXA3112
FITS RVK3500



GRAPHITE LUBE PLATE RVXA3101



COUPLER LOCK RVXA3107



LIFTING DEVICE RVXA3130

“
**AN ACCIDENT RARELY
 HAPPENS WHEN A
 HITCH IS BRAND NEW.
 IT HAPPENS AFTER
 YEARS OF WEAR FROM
 THE ROAD.**

**TAYLOR JONES,
 DIRECTOR OF ENGINEERING**



Watch how
 we test.

WHAT TESTING STANDARDS EXIST TODAY FOR GOOSENECK AND FIFTH WHEEL HITCHES?

SAE J2638 is the standard that establishes the minimum performance criteria for gooseneck and fifth-wheel hitches up to 30,000 lbs. Currently, the standard is a recommended practice and NOT a requirement to sell or use a trailer hitch.

However, I strongly believe that anyone towing a gooseneck or fifth-wheel should be using equipment, whether it's ours or another brand, that has been tested and passes the J2638 standards. I recommend customers ask before buying.

WHAT DOES SAE J2638 REQUIRE?

The standard requires hitches to complete non-independent tests without loss of attachment. This means that if the damage occurred while driving, it would not allow the trailer to separate from the truck.

The nine tests include static tests of force against the hitch in six directions and three dynamic tests of 300,000 cycles each. And while the standard allows you to use a different specimen for each test, my personal requirement for B&W is that a single specimen pass the dynamic tests and then also pass the static tests. I think this reflects what happens in the real world. An accident rarely happens when a hitch is brand-new. It happens after years of wear from the road.

HOW DOES B&W USE THE TESTING STANDARD?

Before we build a trailer hitch, we model it using CAD software. Then, in a digital environment, we subject it to the types of forces we know exist, using FEA (Finite Element Analysis). This modeling gives us a good idea of what we will see on the testing equipment and in real situations. From there, a prototype is built and we run it through the full gamut of J2638 tests at the max tow rating for the truck it is designed to fit.

After the J2638 testing is complete, we also subject our designs to real world testing by using them to tow heavy trailers with different types of loads. We've been collecting data on how hitches perform for a long time. When we see hitches that have been in accidents, it confirms the data that we have. It's reassuring to see our hitches perform on the road the way we predicted in the lab.

TESTING TERMINOLOGY

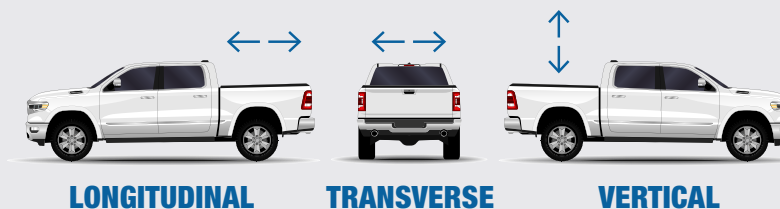

STATIC

Load is applied at an even rate to determine the structural integrity and absolute strength of the structure. Static tests simulate extreme load situations, such as hard braking.

DYNAMIC

A load is applied, released, then applied again to determine the overall structural integrity and its resistance to fatigue failure. Dynamic tests simulate thousands of miles of extreme use.

ON THE ROAD WITH THE ROTHs



THE ROTH FAMILY
Home base: Idaho

WE'VE ALL FELT IT. BURNT OUT AND WANTING SOMETHING MORE. A SIMPLER LIFE. MORE TIME WITH FAMILY. THE ABILITY TO SEE THE WORLD AND WANDER.

The Roth family figured out how to do just that. After years of the corporate grind, they decided enough was enough. So they packed up their four kids and hit the road.

Years of long, unpredictable hours at work had Justin and Erin Roth feeling like precious time with their two young children was slipping through their fingers. Then they found out they were having twins!

"DECIDING TO BECOME FULL-TIME RV TRAVELERS WAS CERTAINLY NOT AN OVERNIGHT PROCESS OR DECISION."

"We had worked our entire lives toward endless goals of 'climbing the ladder.' But, it was evident that attaining

these goals wasn't going to allow us to be the parents we wanted to be. We had to make some tough decisions."

Erin began following some RV families on social media and seeing how their lives were being enriched in ways the Roths had never thought possible. "It just felt right for some reason. We started running the numbers and realized how simplifying our lives and eliminating the things that didn't have value toward our happiness could actually create time, togetherness and ultimately fulfillment," said Justin.

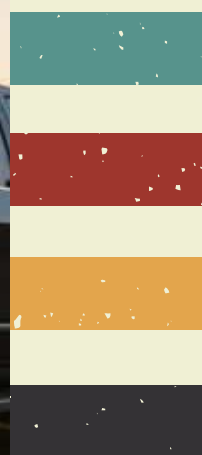

As they started planning full-time travel, it began to dawn on them what life on the road would mean for their family. “We discovered our new parameters for a successful life.”

Once they hit the road, they had to adapt quickly to their new lifestyle, including planning adventures ahead. “The way we plan has certainly evolved over time,” Justin said. “We booked our schedule solid and had that peace of mind to start out. Our very first campground reservation was for two weeks. We were gone after eight days. There was too much to experience to be sitting stationary for two full weeks. Eventually, we learned that flying by the seat of our pants, essentially winging it, was more our style.”

When they started to find their groove, the Roth family began experiencing the benefits they were searching for. More time together, exploring this beautiful country, and even making lasting connections with other RV families. “Hands down, the most surprising thing about this lifestyle is the community.”

“WE HAVE MADE LIFELONG FRIENDS BY PULLING IN NEXT TO ANOTHER RV WITH KIDS’ BIKES IN TOW ON BLM LAND IN THE MIDDLE OF THE DESERT.”

“When you meet a new traveling family, you immediately have a ton in common and move from ‘Hello, nice to meet you.’ to your kids running in and out of each others’ campers all day long and cooking every meal together.”



ROTH FAMILY RULES

**LESS WORRY,
MORE FUN.**

**LESS BUSY,
MORE TIME.**

**LESS STUFF,
MORE LIFE.**



16K HEAVY-DUTY

RECEIVER HITCH

THE STRONG

SILENT TYPE

Designed for heavy-duty towing, this receiver hitch offers super-simple, bolt-on installation with minimal to no drilling. Its fully welded construction gives you a 1,600-pound tongue weight and 16,000-pound towing capacity. The black powder coated finish and zinc-plated bolts help prevent rust and corrosion.

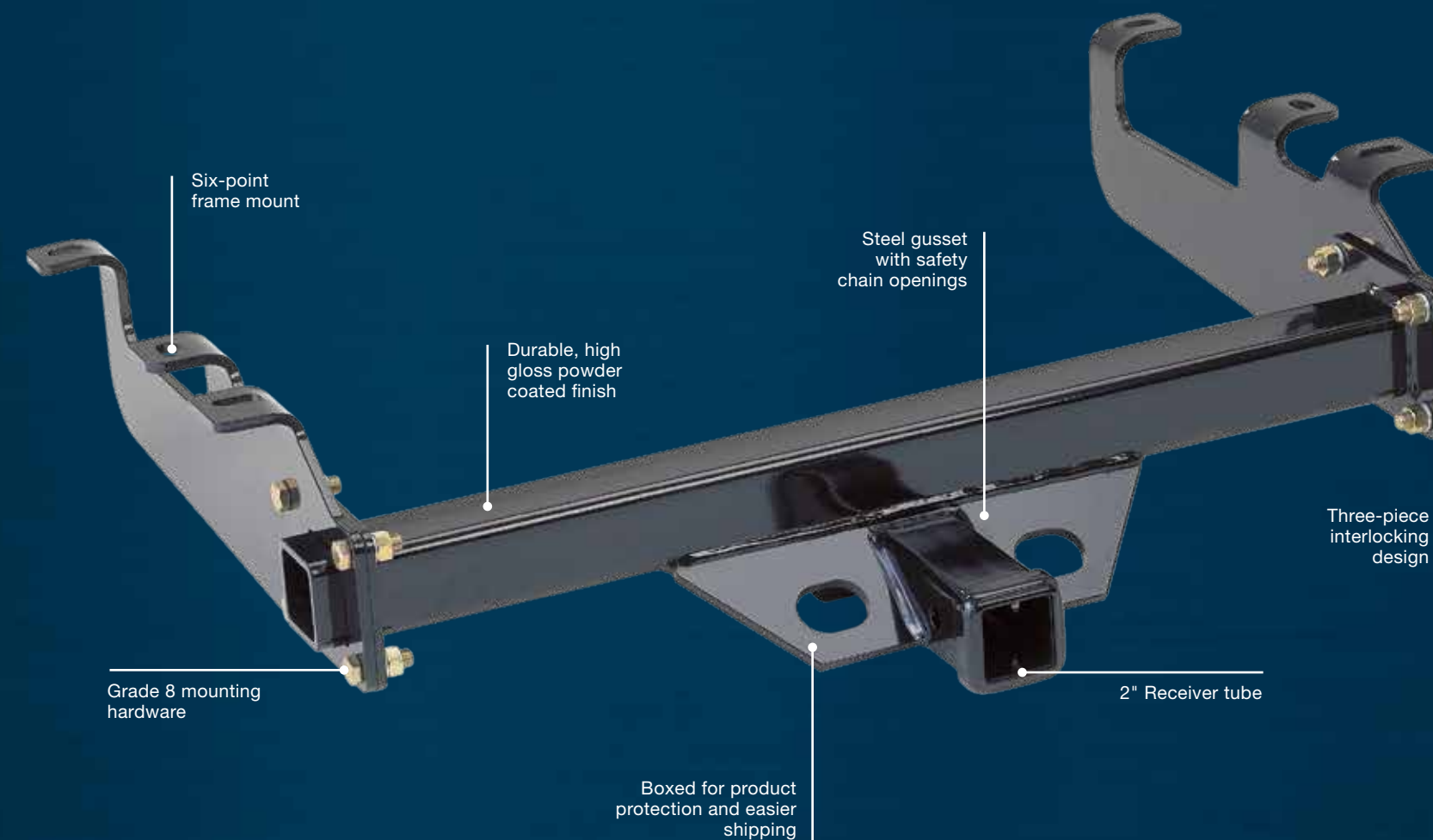

16,000 lb GTW
1,600 lb VTW

ACCESSORIZE TO PERFECTION

B&W offers a wide range of durable accessories that adapt to your specific setup.



HEAVY-DUTY BALL MOUNTS

HIGH-GLOSS POWDER COATED FINISH

Part #	Drop	Shank
BMHD30010	2" Drop	2" x 6" Shank
BMHD30011	2" Drop	2" x 8" Shank
BMHD30012	4" Drop	2" x 6" Shank
BMHD30013	4" Drop	2" x 8" Shank
BMHD30014	6" Drop	2" x 6" Shank
BMHD30210	2" Drop	2.5" x 6" Shank
BMHD30212	4" Drop	2.5" x 6" Shank
BMHD30214	6" Drop	2.5" x 6" Shank



16,000 lb GTW
1,600 lb VTW

TRIPLE TOW BALL MOUNT

HIGH-GLOSS POWDER COATED FINISH

1-7/8" ball	3,500 lb GTW
2" ball	7,500 lb GTW
2-5/16" ball	10,000 lb GTW

Part #	
BMTT31004	Triple Tow Ball Mount



10,000 lb GTW
1,000 lb VTW



SPECIALTY AND HEAT-TREATED HITCH BALLS

MACHINED FROM CARBON STEEL

Part #	Ball Diameter	Shank Diameter	Shank Length	Max Load	Rise	Threads Per Inch	Finish
HB94001	2-5/16"	1"	2-1/2"	12K	No Rise	14	Heat Treated
HB94002	2-5/16"	1-1/4"	2-1/2"	24K	1"	12	Heat Treated
HB94003	2-5/16"	1-1/4"	3-1/4"	24K	1"	12	Heat Treated
HB94004	2-5/16"	1-1/4"	2-1/2"	30K	No Rise	12	Heat Treated
HB94005	2-5/16"	1-1/2"	2-3/4"	30K	1"	12	Heat Treated
HB94006	2-5/16"	1-1/2"	2-3/4"	30K	2"	12	Heat Treated
HB94007	2-5/16"	1-3/8"	2-3/4"	30K	1"	12	Heat Treated
HB94008	3"	2"	3-1/4"	30K	No Rise	12	Heat Treated
HB94009	2-5/16"	2"	3-1/2"	30K	No Rise	4.5	Heat Treated
HB94011	2-5/16"	2-3/16"	4"	30K	No Rise	n/a	Heat Treated
HB94012	Ball Collar	2.188 ID	2" Tall				Untreated
HB94013	Ball Collar	2.188 ID	3" Tall				Untreated
HB94050	2-5/16"	1-1/4"	2-1/2"	16K	No Rise	12	Chrome



Heat Treated



Chrome Finish

HEAVY-DUTY PINTLE PLATE

HIGH-GLOSS POWDER COATED FINISH

Part #	Hole	Position	Shank
PMHD14001	6 Hole	2 Position	2" x 9" Shank
PMHD14002	8 Hole	3 Position	2" x 9" Shank
PMHD14003	8 Hole	3 Position	2" x 11" Shank
PMHD14004	14 Hole	6 Position	2" x 13" Shank
PMHD14005	14 Hole	6 Position	2" x 15" Shank
PMHD14202	8 Hole	3 Position	2.5" x 9" Shank



CLASS
V

16,000 lb GTW
1,600 lb VTW

REDUCER SLEEVES

SLIDES DIRECTLY INTO HITCH OR ONTO SHANK

Part #	From	To
RHXA2182	2.5" x 2.5"	2" x 2"
RHXA2183	3" x 3"	2.5" x 2.5"

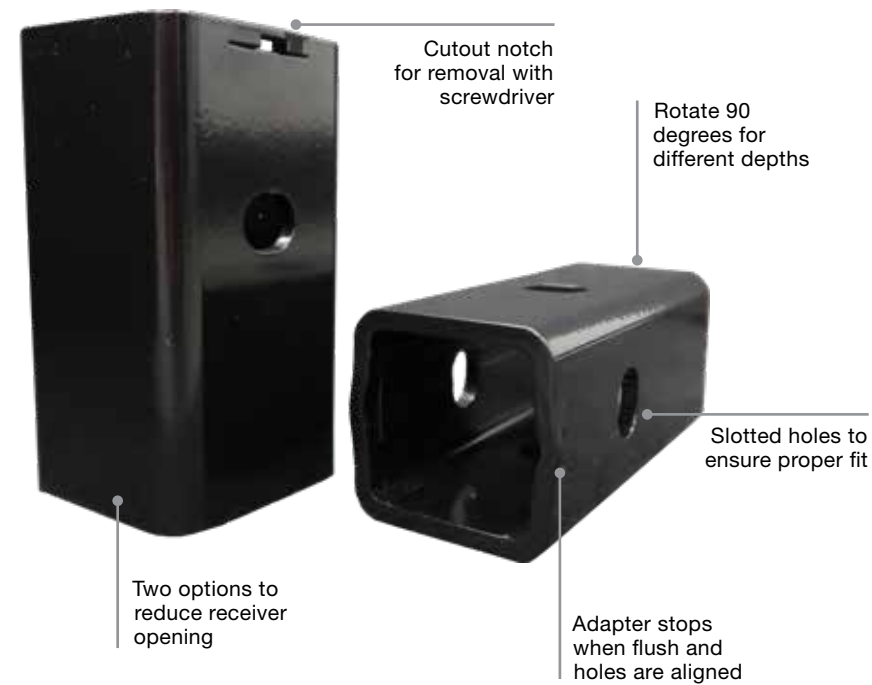



CAB PROTECTORS

A CAB PROTECTOR WITH BENEFITS

There's not much standing between you and the heavy load you're towing. But our cab protector isn't just about protection. It looks great and has plenty of usable features. Our truck specific, powder coated protectors are outfitted with LED lights, tie-down brackets and grab handles.



OPTIONAL BEACON LIGHT BRACKET



Light not included

OPTIONAL LIGHT BAR BRACKET



Light not included



BECAUSE YOUR BIKE DOESN'T WANT TO BE TIED DOWN EITHER

The Biker Bar is a clean clamping system that attaches to your Harley Davidson's frame for solo loading in under a minute. No more cumbersome straps, chocks or bolt-on contraptions that can damage paint, chrome and leather and put unnecessary stress on your suspension. Biker Bar is the fastest, most secure, best-looking way to load and haul your bike.



BIKER BAR

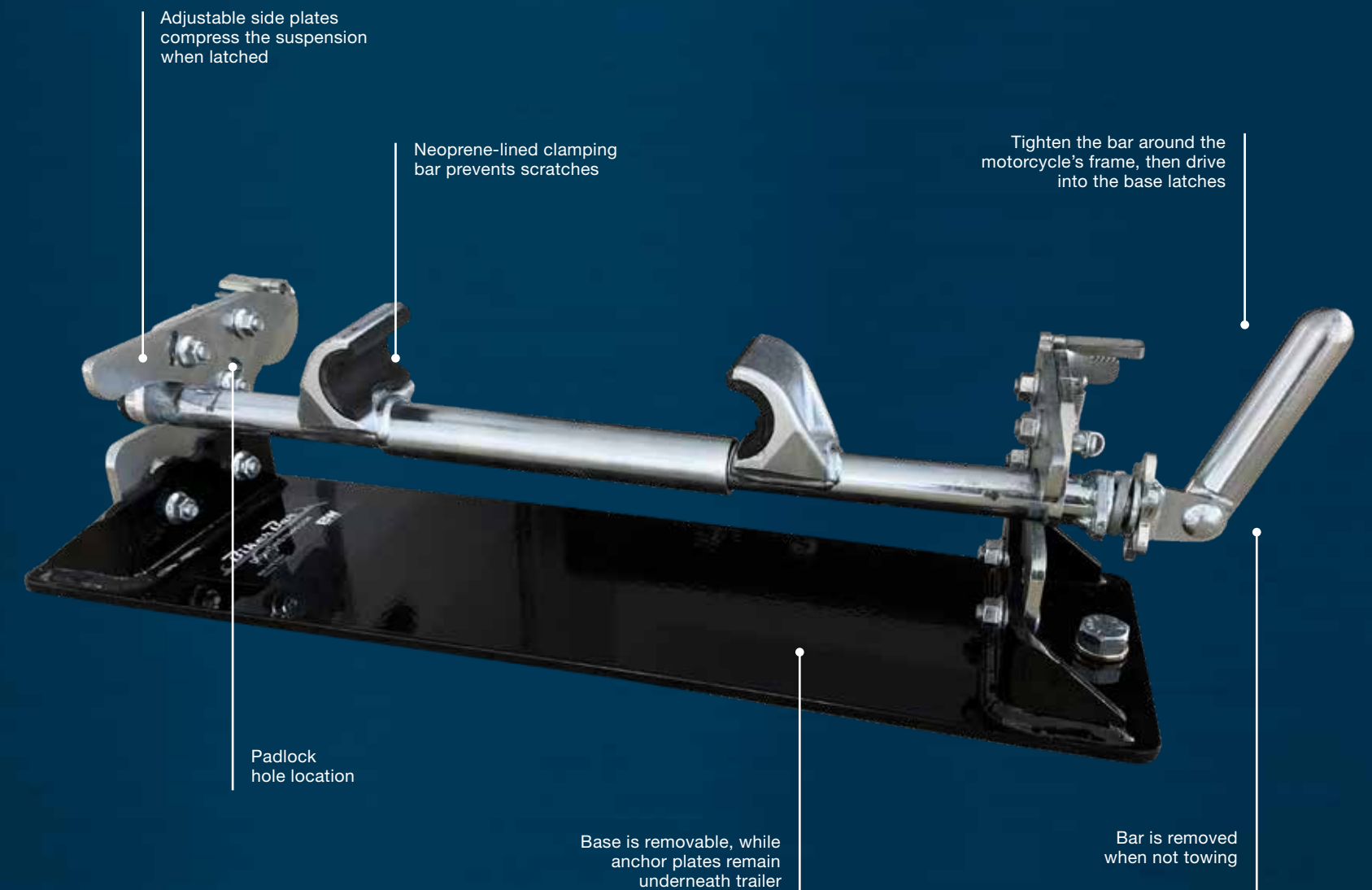

SHOW YOUR AMERICAN-MADE PRIDE WITH AUTHENTIC B&W GEAR

Shop our collection of gear and accessories, perfect for an honest day's work or a weekend adventure.

To get some B&W Gear of your own, head over to [bwtrailerhitches.com/bw-gear](https://www.bwtrailerhitches.com/bw-gear).



YEAH, THAT'S COVERED

PLAIN TALK ABOUT OUR WARRANTY

We are confident that our products are made without design or quality defects. However, if you believe that one of our products doesn't live up to our standards, we would make it right with you, our customer.

If your product suffers damage because of an accident or misuse on your part, we will work to get you back on the road with as little cost and hassle to you as possible, because that is just being a good neighbor.

We can't keep your product in 'new' condition. Your product, and the finish will age through normal wear and tear. You should only use our products in the manner intended in their design. Most of our products require some maintenance to continue to work as they did when they were new.

We appreciate it when our customers register their products with us. However, we offer our warranty even if you don't.

To register your product or download a copy of our limited lifetime warranty, visit www.bwtrailerhitches.com/warranty.

